

DX100ULM

Power Supply / Charger for Access Control and Egress Doors.

This power supply should be installed in compliance with the National Electrical Code(NFPA 70) CSA C22.1, Canadian Electrical Code, Part 1, and all applicable Local Codes. Installation to be performed by suitably qualified technical personnel.

Description

The DX100ULM is a power supply / charger that supplies a total of 1.5 amps nominal continuous supply current at nominal 12/24VDC outputs. There are 2 outputs for Magnetic lock or door strike each with electronic over-current protection @ 1 Amp. It is installed in a large mild steel metal enclosure capable of accommodating two 7AH or 12AH lead-acid rechargeable Batteries. The unit can provide maximum 1.0A battery charging current. These are monitored Power Supplies for use in Access Control and Egress Doors. Listed under the UL294, CAN/ULC-60839-11-1 and CAN/ULC-S533.

General Specifications:

1. Input = 100-240VAC, 50-60Hz. 2.4A Max.
2. Output 1.5 Amps continuous supply current at Nominal 12/24 VDC controlled outputs and one auxiliary output.
3. 2 Magnetic Lock or 2 Strikes outputs each, with electronic over-current protection set at 1 Amp.
4. Built-in dedicated charger for sealed lead acid or gel cell type batteries.
5. Maximum battery charging current 1 Amps.
6. Yellow LED for Battery Fault indication including charger failure monitor.
7. Battery presence detection within 10 seconds.
8. Battery Charger Monitor.
9. Battery load test every 48hr.
10. Battery Reversal protection.
11. Low Battery indication at 11.40/22.80 Volts
12. Low Battery disconnect at 10.10/20.30 Volts.
13. Automatic switch over to stand-by battery upon AC Failure.
14. Common "Batt.Fault" CMOS relay for all battery and charger fault.
15. AC input indication by Green LED. (LED on when AC is present).
16. CMOS relay output for AC failure within 60 seconds.
17. LEDs display on enclosure door (LEDs, Green, Yellow).
19. Common "Out Fault" CMOS relay for DC failure on any of the 4 outputs.
20. Battery charging leads included.
21. Board Dimension: 195mm x 110mm
22. Enclosure Dimension: 323mm x 331 mm x 110mm.

Technical Specification:

Controlled Outputs(2)	Nominal 12 VDC or 24 VDC, Max. 500mA each Max.13.80 VDC or 27.60 VDC, Min. 11.40 VDC or 22.80 VDC
Auxiliary Output	Nominal 12 VDC or 24 VDC, Max. 500mA Max.13.80 VDC or 27.60 VDC, Min. 11.40 VDC or 22.80 VDC
Charging Current	Max. 1Amp
Reset & Fire Trigger Input	Max. Wire Resistance 100 ohm
Operating Temperature	0 deg.C to 49 deg.C

Performance Ratings

UL 294 Performance Levels:

Model	Product Type	Line Security	Destructive Attack	Endurance	Standby Power
DX100ULM	Power Supply	I	I	IV	III (when used with 7Ah battery) IV (when used with 12Ah battery)

CAN/ULC-60839-11-1 Performance:

Model	Product Type	Grade	Grade Achievement
DX100ULM	Power Supply	3 (when used with 7Ah battery) 4 (when used with 12Ah battery)	To achieve Grade 3 or 4 connects, the Trouble AC & Battery Relay Outputs to a Grade 3 or 4 Control Unit.

LED Indications

1. Green LED - AC indicator

- a. On when AC present.
- b. The normally closed (NC) AC Fault Cmos Relay activates(open) within 60 seconds after AC failure.

2. Blue LED – DC Power indicator

- a. Powered directly from the power supply DC output and indicates output is present. Blue LED will be OFF when no DC is present.

3. Yellow LED – Battery Charger and Fault indicator

- a. The Yellow LED indicates various Battery Fault Conditions and Indication. See the table Fault Condition.

4. Red LED –Battery Test indicator.

- a. The Red LED indicates a Battery test Failure or a Battery charger failure in conjunction with the Yellow LED to indicate other Fault Conditions. See the Fault Conditions and Indication Table for details.

5. Red Led on individual output indicator

- a. There are 2 Red LEDs indicating that the outputs are ON when lit.

Relay Outputs:

Output	Output Type	Description
AC FAIL RELAY	NORMALLY CLOSED OPEN = FAULT	TRIPS WITHIN 60 SEC. AFTER AC FAILS CMOS RELAY RATING: 30VDC 60mA 16 OHMS
BATTERY FAIL RELAY	NORMALLY CLOSED OPEN = FAULT	BATTERY PROBLEM CMOS RELAY RATING: 30VDC 60mA 16 OHMS
DC FAIL RELAY	NORMALLY CLOSED OPEN = FAULT	ONE OF THE 4 OUTPUTS SHORTED OR OVERLOADED CMOS RELAY RATING: 30VDC 60mA 16 OHMS
STATUS OUTPUT RELAY FACP or ACP	FORM C	TRIP WHEN FIRE ALARM IS GENERATED FROM FACP OR ACCESS CONTROL PANEL DRY CONTACT RELAY RATING: 28VDC 300mA, PF 1

Fault Condition & Indications:

FAULT	LED-G	LY	LG	RED LED 5	RED LED 1 - 2	BATT RELAY	AC RELAY	STATUS OUT RELAY	DC RELAY
BATTERY REVERSED OR NOT CONNECTED		ON				OPEN			
BATTERY LOW		ON				OPEN			
BATTERY DISCONNECTED		ON				OPEN			
BATTERY TEST FAIL		ON		5 RAPID FLASHES STOP 1 SECOND REPEAT UNTIL BATTERY IS REPLACED		OPEN			
BATTERY TEST OK		OFF		THREE FLASHES 1 SEC ON/OFF					
AC FAIL	OFF						OPEN WITHIN 60 SEC		
OUTPUT 1-4 FAIL					OFF				OPEN
Fire/ACP TRIGGER ACTIVATED			OFF					OPEN	
RESET/REX TRIGGERED WHEN FIRE/ACP TRIGGER IS NOT ACTIVATED			OFF					OPEN	
BATTERY CHARGER FAULT		ON		10 FLASHES 2 SEC STOP REPEAT UNTILL CHARGER OK		OPEN			

Operating Values

Parameter	Value	Description
Battery Disconnect voltage	10.10V 20.20V	When AC is off, the battery is disconnected when the battery voltage drops below this value. The battery is only reconnected when the AC is restored.
Minimum battery voltage to pass battery test	11.50V 23.0V	Red Led Flash 1 sec ON/OFF during 2 minutes testing. Battery Fail 5 rapid flashes and 1 sec pause. Replace Battery
Voltage low warning	11.40V 22.80V	If the output voltage drops below this value a voltage low warning is generated. See Fault Conditions and Indication

Fire Alarm/Access Control Interface

1) Normally Open (NO), Normally Closed input from the FACP or ACP are available to trigger the DX100ULM operation. Connect the NO or NC from the FACP or ACP output to the FIRE/ACP TRIGGER terminals. Install the 2K2 Ohm end of line resistor (EOLR) provided at the FACP or ACP as shown on the diagram. Fig 1.

REX/Engineering Reset Input

This option is available when the Jumper **JL** is removed (JL OFF). This will cause the DX100ULM to latch upon receiving alarm from the FACP or ACP with this option in place and when the FIRE/ACP TRIGGER resets, DX100ULM will only reset by activating the RESET/REX input.

JL ON will cause the unit to follow the FIRE/ACP TRIGGER. Install the 2.2KOHM RESISTOR, Part #EORL-PWX2K2 provided at the Key Switch or Push Button to perform this operation.

Cascade Connection

Two(2) or more DX100ULM units can be connected together as follows: Connect the STATUS OUTPUT relay **C** and **NC** terminals from the 1st unit to the **RESET/REX input** of the 2nd unit (not polarity sensitive) and remove jumper **JR** of the 1st unit. Install 2.2KOHM RESISTOR, PART #EORL-PWX2K2 on 2nd unit FIRE/ACP TRIGGER. If a 3rd unit is used **JR** must be removed from the 2nd unit and so on for any additional unit. Also 2K2 EOLR must be installed on 3rd unit and so on. Note: Maximum 20 units allowed.

NOTE: If Latch Mode is used, only **JL** jumper on the first unit must be removed. Engineering Reset will be performed from the 1st unit.

Installation Instructions

This power supply should be installed in compliance with the National Electrical Code(NFPA 70), CSA C22.1, Canadian Electrical Code, Part 1 and all applicable Local Codes. Installation to be performed by suitably qualified technical personnel.

- 1 Mount the power supply in the desired location using the 4 mounting holes.
NOTE: For use in Indoor Protected Area with Controlled Environment only.
Do not Install Power Supply on Exterior Doors.
- 2 With the Mains power disconnected, connect the AC leads to the AC Input Terminal Block, respecting the wiring phase and polarity :
Ground/Earth=Green/Yellow, Neutral = Blue (White), Live =Black (Brown). This equipment must be connected to the 120-240 Volt Mains via a readily dedicated accessible external disconnect device with maximum 15 Amp branch protection. Select the operating output DC voltage 12/24 with the jumper. Jumper ON=12VDC, Jumper OFF=24VDC.
- 3 ***Do not connect the battery at this time.***
- 4 Switch ON the AC. Green LED will come ON indicating AC is present and the AC Fault Relay will be energized "ON" (closed). When the AC is off the AC Fault Relay will drop open within 60 seconds (Factory set) activating the C-Mos output contact "AC Fail". Connect this output to relevant monitoring devices.
- 5 Verify the DC output voltage is correct = 13.80VDC or 27.60VDC max. Blue DC LED will be ON to indicate DC output is OK.
- 6 Yellow LED will be on and the BAT FAULT C-Mos relay open indicating the Battery is not present.
- 7 Connect the Battery or Batteries respecting the polarity. Battery shall not be connected if AC is not present first.
- 8 If the battery is connected with the correct polarities the Yellow LED will turn OFF (See Table Fault). Within one minute the Battery Fault Relay will restore (Normally close). Connect this output to relevant monitoring devices.
- 9 If the battery is connected reverse polarity, the Yellow LED will be ON. (See the Table Fault). The CMOS relay will open indicating Battery Fault.
- 10 Connect the devices to be powered to the output terminals +DC LOCK or +DC STRIKE and NEGATIVE(2 outputs). Connect device to auxiliary output terminal block -DC+. 11 If Tamper Switch is required use part # TSW1-02 or TWS2-02, see Fig 3.
- 12 Use EOLR (end of line resistor) Part #EORL-PWX2K2
- 13 Connect the fault relays to FACP or ACP for trouble indication.
- 14 Secure the enclosure with the screw or with the Key Lock if provided.

DX100ULM

ACCESS CONTROL POWER SUPPLY CHARGER
UL,ULC LISTED AS FOLLOWS:
UL294,CAN/ULC-60839-11-1, CAN/ULC-S533

Rated according to CAN/ULC-60839-11-1
Grade 3 (with 7Ah Battery)
Grade 4 (with 12Ah Battery)



Date of MFG

NOTE: PLEASE REFER TO DX100ULM INSTALLATION MANUAL PART NO: YY1000 REV:01

PART NO: YY1001 REV:01

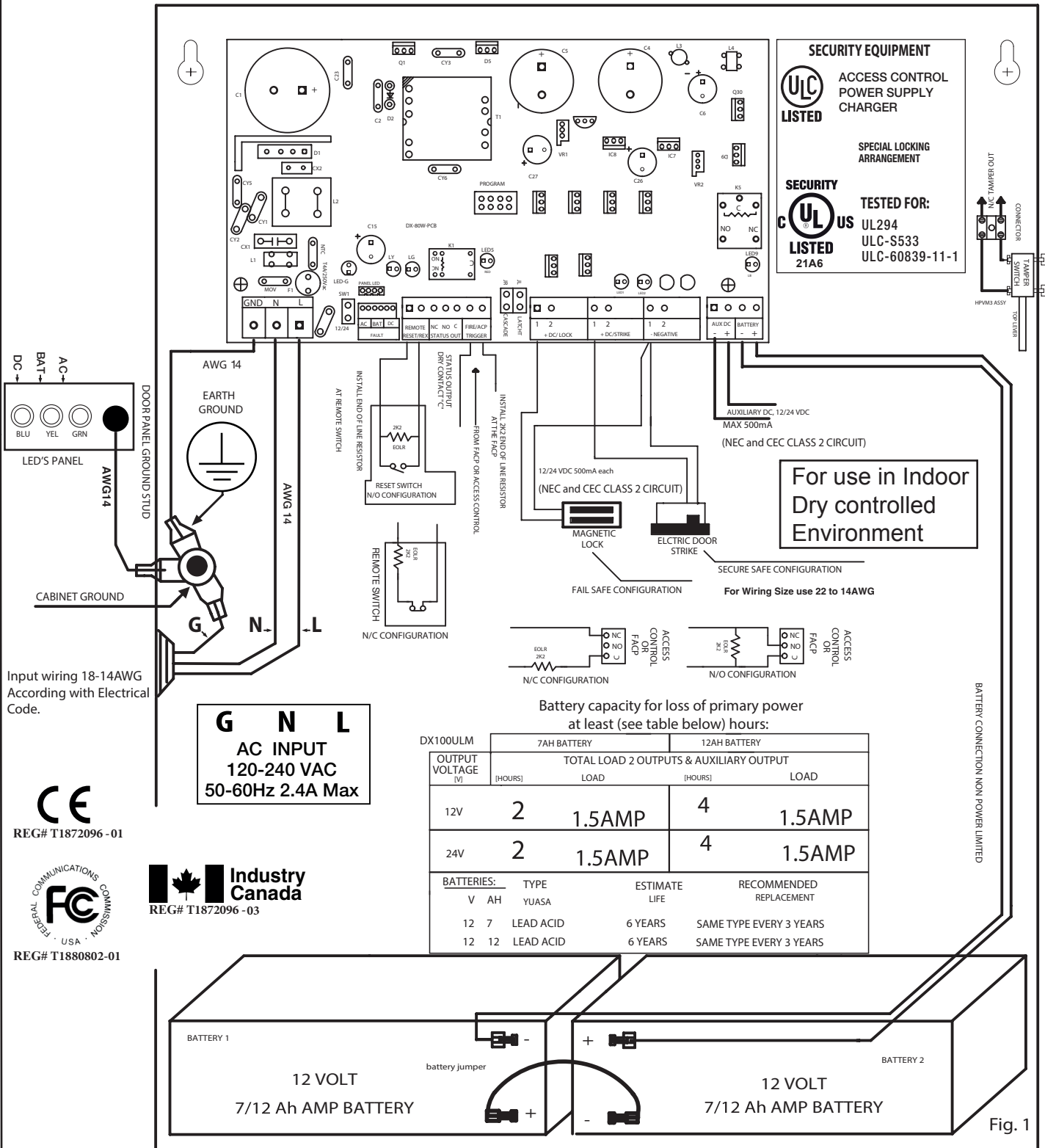

SECURITY EQUIPMENT

ULC LISTED ACCESS CONTROL POWER SUPPLY CHARGER

SPECIAL LOCKING ARRANGEMENT

SECURITY LISTED TESTED FOR: UL294 ULC-S533 ULC-60839-11-1

For use in Indoor Dry controlled Environment

Input wiring 18-14AWG According with Electrical Code.

G N L
AC INPUT
120-240 VAC
50-60Hz 2.4A Max

Battery capacity for loss of primary power at least (see table below) hours:

OUTPUT VOLTAGE (V)	7AH BATTERY		12AH BATTERY	
	(HOURS)	LOAD	(HOURS)	LOAD
12V	2	1.5AMP	4	1.5AMP
24V	2	1.5AMP	4	1.5AMP

BATTERIES:	TYPE	ESTIMATE LIFE	RECOMMENDED REPLACEMENT
V AH	YUASA		
12 7	LEAD ACID	6 YEARS	SAME TYPE EVERY 3 YEARS
12 12	LEAD ACID	6 YEARS	SAME TYPE EVERY 3 YEARS

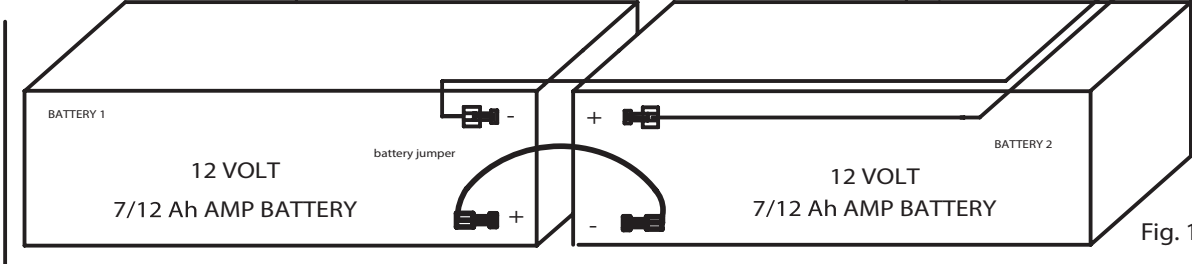

Fig. 1

KEEP POWER LIMITED WIRING FROM NON POWER LIMITED WIRING AT LEAST 0.25" INCH APART

2 DX100ULM Cascade Connection



ACCESS CONTROL POWER SUPPLY CHARGER

UL,ULC LISTED AS FOLLOWS:

UL294,CAN/ULC-60839-11-1 and CAN/ULC-S533 POWER SUPPLY FOR ACCESS

CONTROL SYSTEM NOTE: PLEASE REFER TO DX100ULM INSTALLATION MANUAL PART NO: YY1000 REV:01

PART NO: YY1002 REV:01

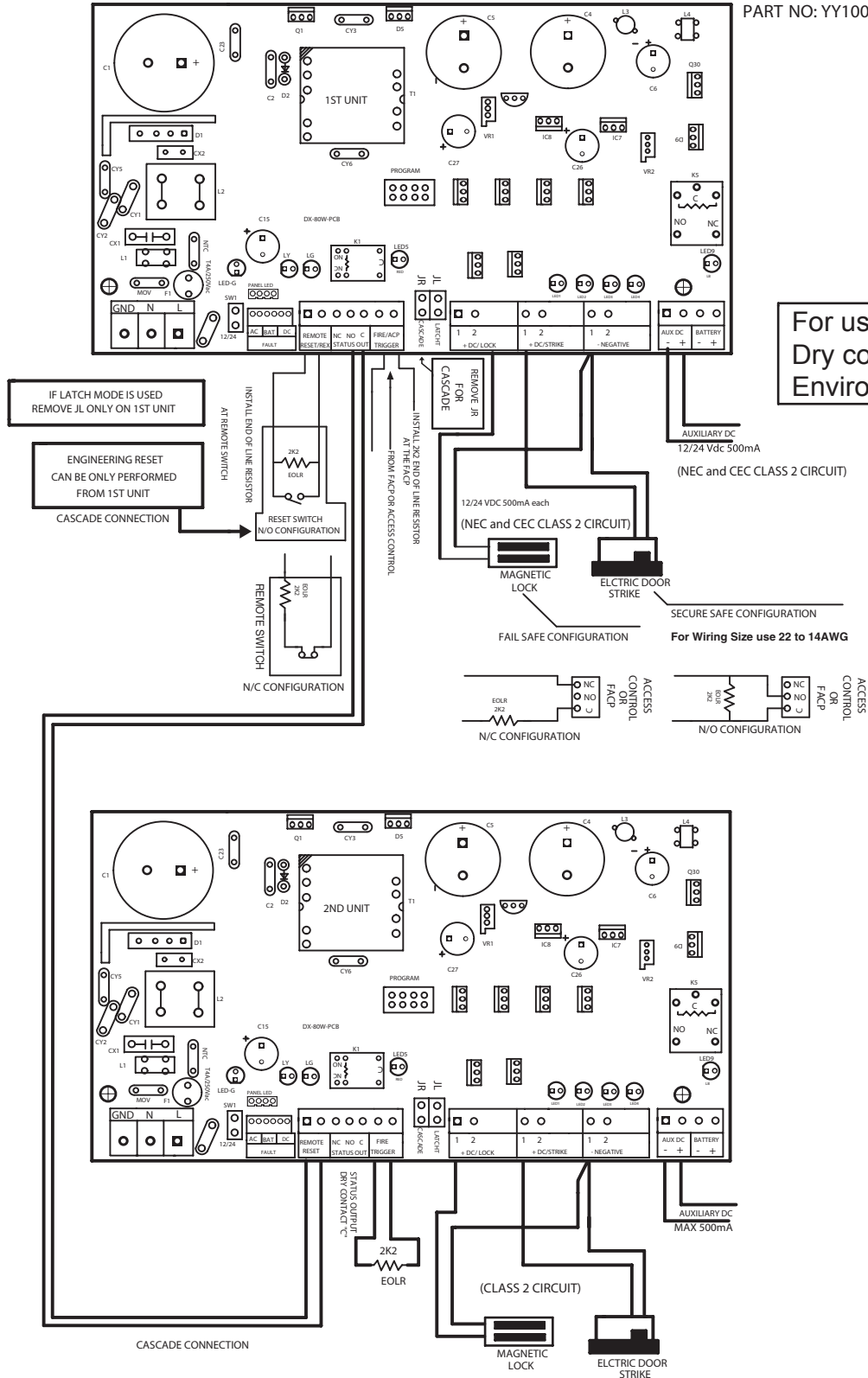

For use in Indoor Dry controlled Environment

Fig. 2

KEEP POWER LIMITED WIRING FROM NON POWER LIMITED WIRING AT LEAST 0.25" INCH APART

Tamper Switch Connection

PART NO: YY1003 REV.01

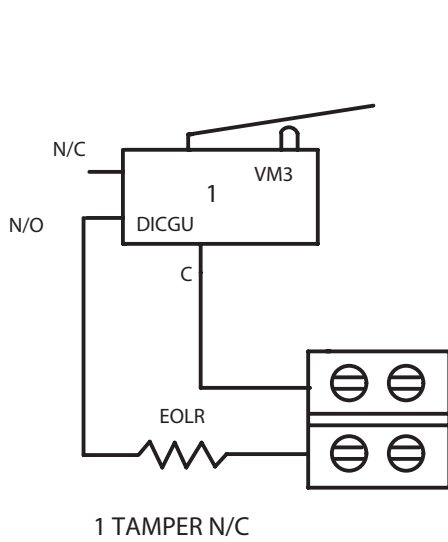

CONNECT TO MONITORING POINT

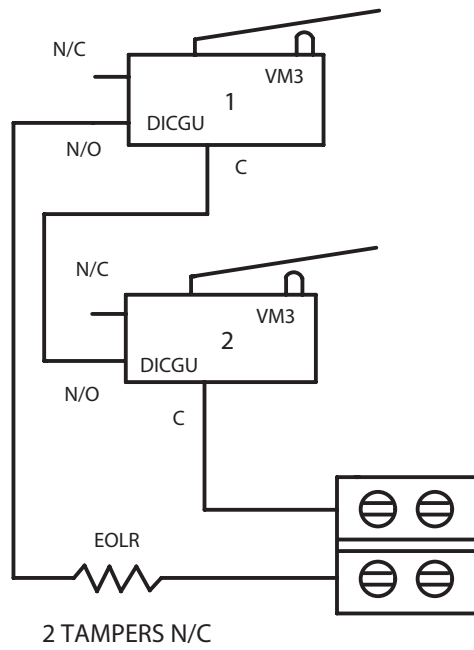

CONNECT TO MONITORING POINT

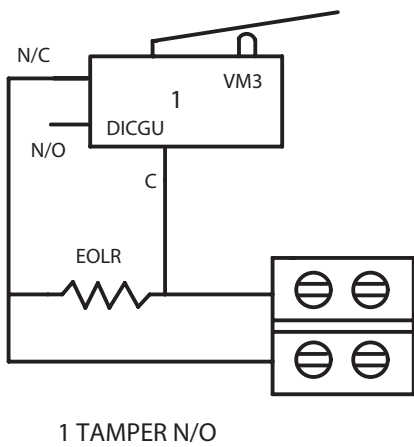

CONNECT TO MONITORING POINT

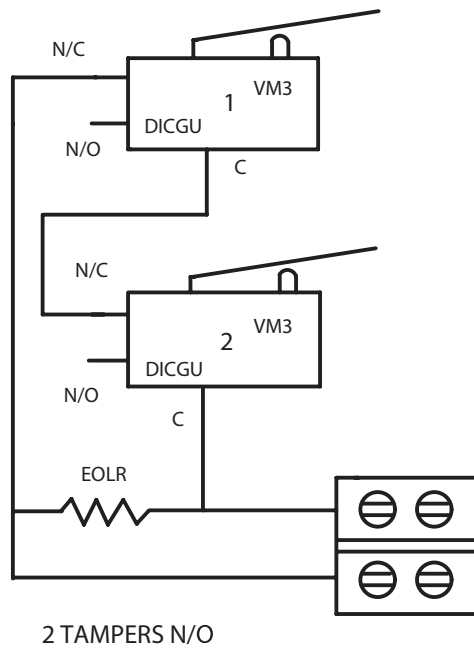

CONNECT TO MONITORING POINT

Fig. 3